

REVISION HISTORY				
ZONE	REV	DESCRIPTION	DATE	BY
-	00	ORIGINAL ISSUE	6/18/15	GCP

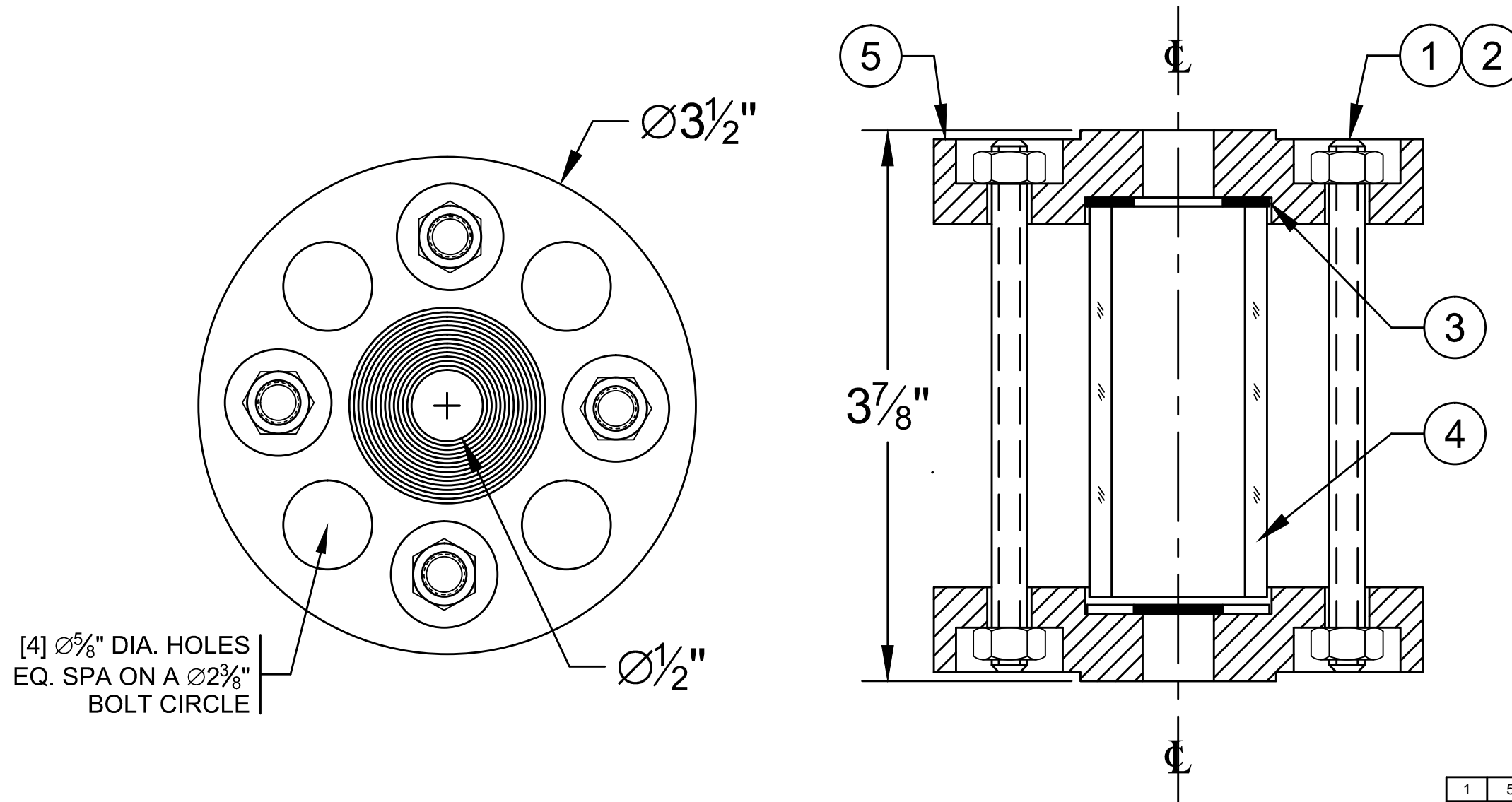

QTY	SYM	PART NUMBER	DESCRIPTION
1	5	XXXX-XXXX-XXXX	HEAD
1	4	XXXX-XXXX-XXXX	CYLINDER
1	3	XXXX-XXXX-XXXX	GASKET
16	2	XXXX-XXXX-XXXX	HEX NUT
4	1	XXXX-XXXX-XXXX	THREADED STUD
BILL OF MATERIAL			

UNLESS OTHERWISE NOTED:
 DIMENSIONS ARE IN INCHES.
 DIMENSIONS ARE SYMMETRICAL ABOUT CENTERLINES.
 BREAK CORNERS, REMOVE BURRS.
 CASTING FILLET RADII: 1/8" R
 CAST CORER RADII: 1/16" R

MACHINING TOLERANCES:
 FRACTIONS: + 1/64
 DECIMALS: +/- 0.010
 ANGLES: + 1/2 deg
 FILLET RADII: 1/32" R
 MACHINED FINISH: RA 125u in
 @ 1, 2, 3, 4, 5 WITHIN 1/64 FIM

NOTES:
 MAX RATING: 150PSI/FV@100°F
 MAX TEMPERATURE: 500°F*



MODEL#: 1/2" LIF
 1/2" 150# FLANGED FULL VIEW SIGHTFLOW INDICATOR

ASME CODE CALCULATIONS AND ANY RESULTING ADDITIONAL MATERIAL NEEDED TO REINFORCE SIGHT GLASS OPENING TO MEET ASME CODE IS THE RESPONSIBILITY OF THE VESSEL MANUFACTURER.

* w. proper gasket selection. Consult Factory

THIS DRAWING IS THE SOLE PROPERTY OF THE J.G. PAPAILIAS COMPANY, INC AND NEITHER THE DOCUMENT NOR THE INFORMATION CONTAINED HEREIN SHALL BE COPIED, REPRODUCED, DISCLOSED OR TRANSFERRED EXCEPT AS AUTHORIZED IN WRITING BY AN OFFICER OF THE J.G. PAPAILIAS CO., INC.

DRAWN:	GCP	6/18/15	SIZE	CAGE CODE	DRAWING NUMBER	REV
CHECKED:	GCP	6/18/15	B	1Z740	03L008	0
APPROVED:	GCP	6/18/15	SCALE: 1:1	EST. WEIGHT: 3 LB [2 KG]	SHEET: 1 OF 1	

- Notes:
1. Flanged Ends Mate to 1/2" ANSI 150# B16.5 RF
 2. Perform ambient temperature hydrotest at 1.5 times operating pressure.
 3. All units supplied with a 304 Stainless Steel Tag.
 4. Maximum Rating: 150 PSI/FV@100°F